

# A 12 Volt Standby Power System

Anthony Whobrey KC4JTV

This simple system will provide a back up source of 12-volt power for your station. It has no moving parts, and is silent while operating.

The major components are a regulated 12-volt power supply of 6 to 20 amp rating, and a 12-volt automotive battery. Many people would use the power supply as a float charger across this battery to produce a simple source of continuous power. This approach is easy, but can be improved with at minimal cost and with little effort.

Place your battery in a safe well-ventilated location. Nearly all batteries produce explosive gas while charging; it is best to have your battery in an area separate from your operating position. My battery box is in a garage adjacent to my shop, with 8-gauge wire running about 15 feet to my radio. I used a plastic box designed to house a trolling motor battery; they are not too expensive.

Always place a fuse at the positive battery terminal; I use a large paper cartridge fuse (non-30). This fuse is available at any electrical supply store. All equipment except the power supply should be connected through this fuse. Use a quality fuse holder and wire of adequate gauge for the fuse rating. Remember that the battery can supply hundreds of amperes for a considerable time, don't cut corners here.

Connect your power supply through a suitable fuse and a large rectifier to the positive terminal of your battery. Place the fuse near the power supply output and the rectifier at or near the positive battery terminal, in this way the wire is protected from a short circuit from both ends. Most power supplies will overcharge a battery; the voltage is usually a bit high. Use of a rectifier will drop the power supply voltage by .7 volt or so and also protect the battery from discharge through the supply during a power outage. Check with the manufacturer of your battery to determine the recommended float charge voltage (generally 12.8 to 13.2 volts). It may be necessary to adjust the power supply voltage slightly, or alternatively, use two rectifiers in series to further reduce the charging voltage.

While running the wiring, it isn't a bad idea to find a place for a 12-volt light. Use an automotive type dome light to supply a handy source of emergency illumination. A couple of sources offer a 12-volt "trouble light" with a magnetic base and retractable cord; they are nice if your budget isn't too tight.

After an outage of a few hours duration, your power supply will recharge the battery within a day or so, depending on its current capacity. In the event of a prolonged outage, consider other means of recharging the battery to near full capacity, before turning on your power supply. Most power supplies in common use are not current limited, and the load presented by a deeply discharged battery may blow the output fuse. If your battery becomes deeply discharged, use an automotive type charger (or your automobile) to bring it to nearly full charge before placing your power supply back in service.

This system is not too expensive to build, and offers instant transfer to back up power; it will switch to or from battery power while your radio is in operation without the slightest interruption. Many commercial and public safety base stations use battery and charger systems, the same concept is also used in telecommunications offices. This system, while on a somewhat smaller scale, will work well for the average emergency operator.

## Schematic:

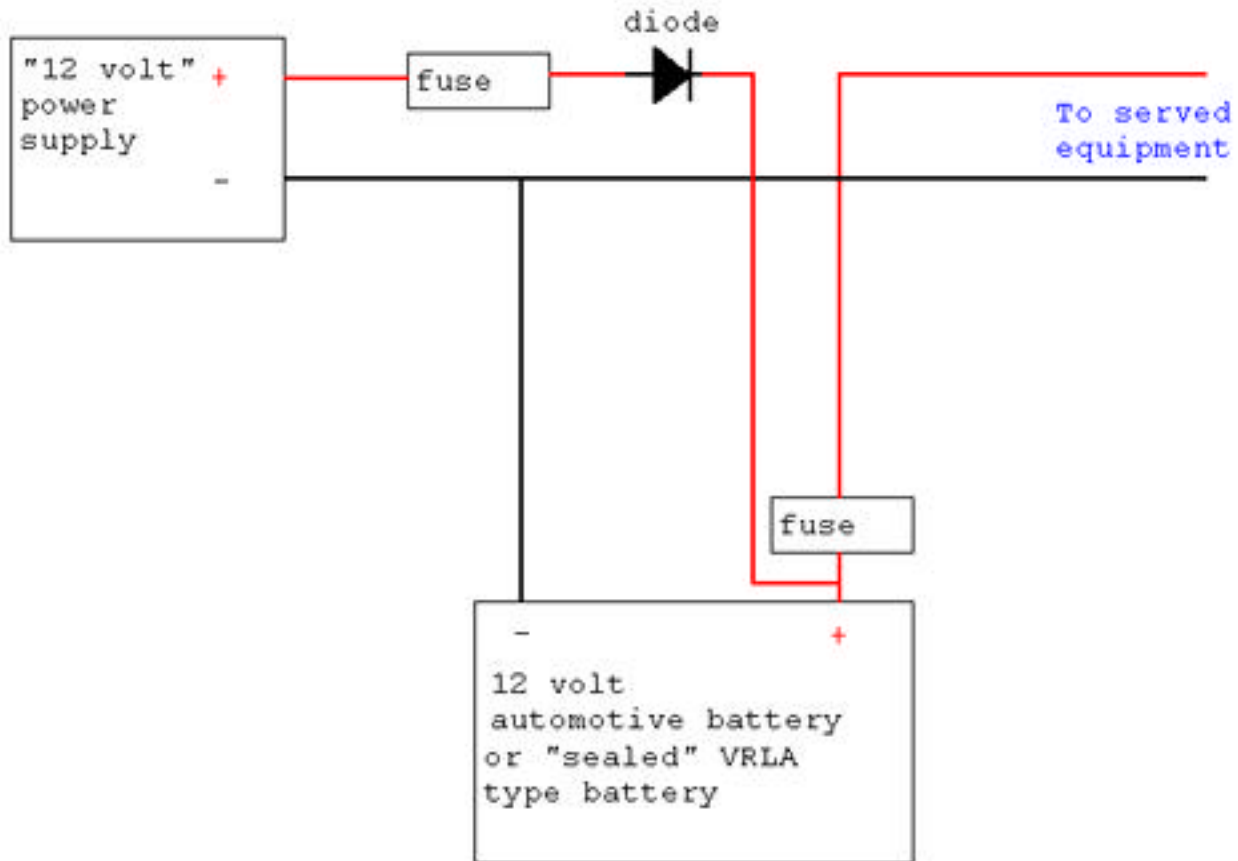

### Notes

1. If a vented battery is used, adequate ventilation should be provided to prevent build up of hydrogen gas.
2. The diode should be capable of passing at least the full rated current of the power supply. A heatsink will probably be required.
3. The value of both fuses should be comparable to the rated power supply current.

### Addendum from Tony, KC4JTV:

I just saw the posting of my article about the 12 volt power system. Today I learned that most Astron power supplies will fail prematurely if they are used directly across a battery. This is due to the feedback of voltage from the battery to the supply when the A.C. power fails; the regulator I.C. will sometimes fail if the voltage on its output is substantially above the voltage on the regulator's input.

I mention this because the article implies that most power supplies can be used directly across a battery. Obviously, such would not be the case with Astron supplies. FYI, The circuit as drawn works well with an Astron supply, I use one myself.